

V500

DUST COLLECTOR

V500 is a cyclone technology dust collector equipped with a fire fighting system which represents an absolute novelty in the footwear sector. The high level of automation guarantees high performance and safety. The self-cleaning system of inner filters reduces maintenance operations and increases their duration. In conditions of fire risk a water nebulizer re-establishes the safety conditions; in case of persistence of danger V500 switches off automatically and activates an acoustic alarm. V500 is a compact, silent and reliable 4.0 aspirator.



TECHNICAL SPECIFICATIONS

GENERAL FEATURES

- Cyclone technology
- Power: 1,5 Kw
- Flow rate: 3200 cm/h
- Weight: 90 Kg
- Sound pressure: 77 Db
- Humidity and temperature control system with alarm siren
- Automatic dust humidification system in the collection bin
- Automatic pneumatic cleaning system

CONFIGURATION

SYSTEM DETAILS

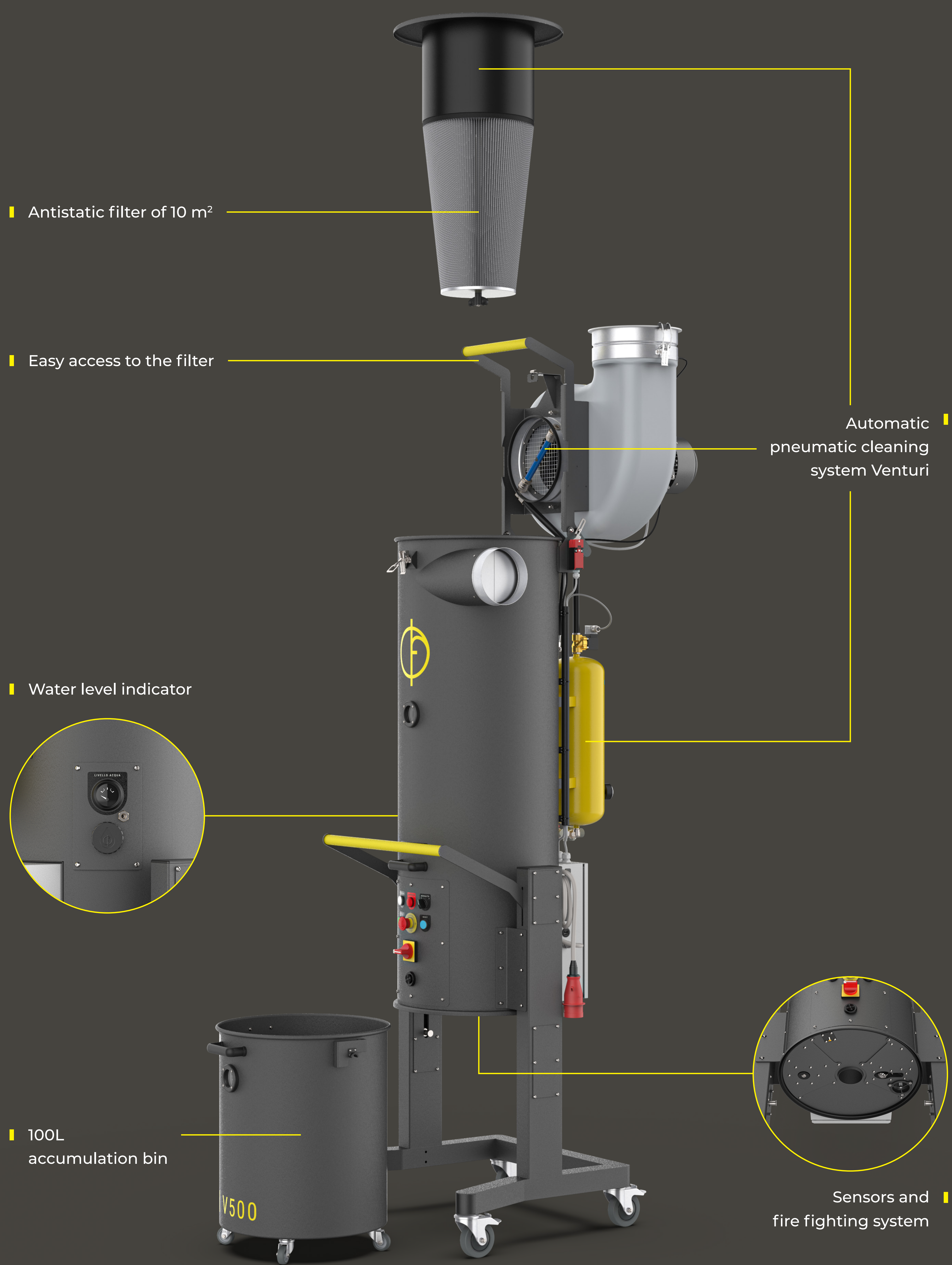

DIMENSIONS

OVERALL DIMENSIONS

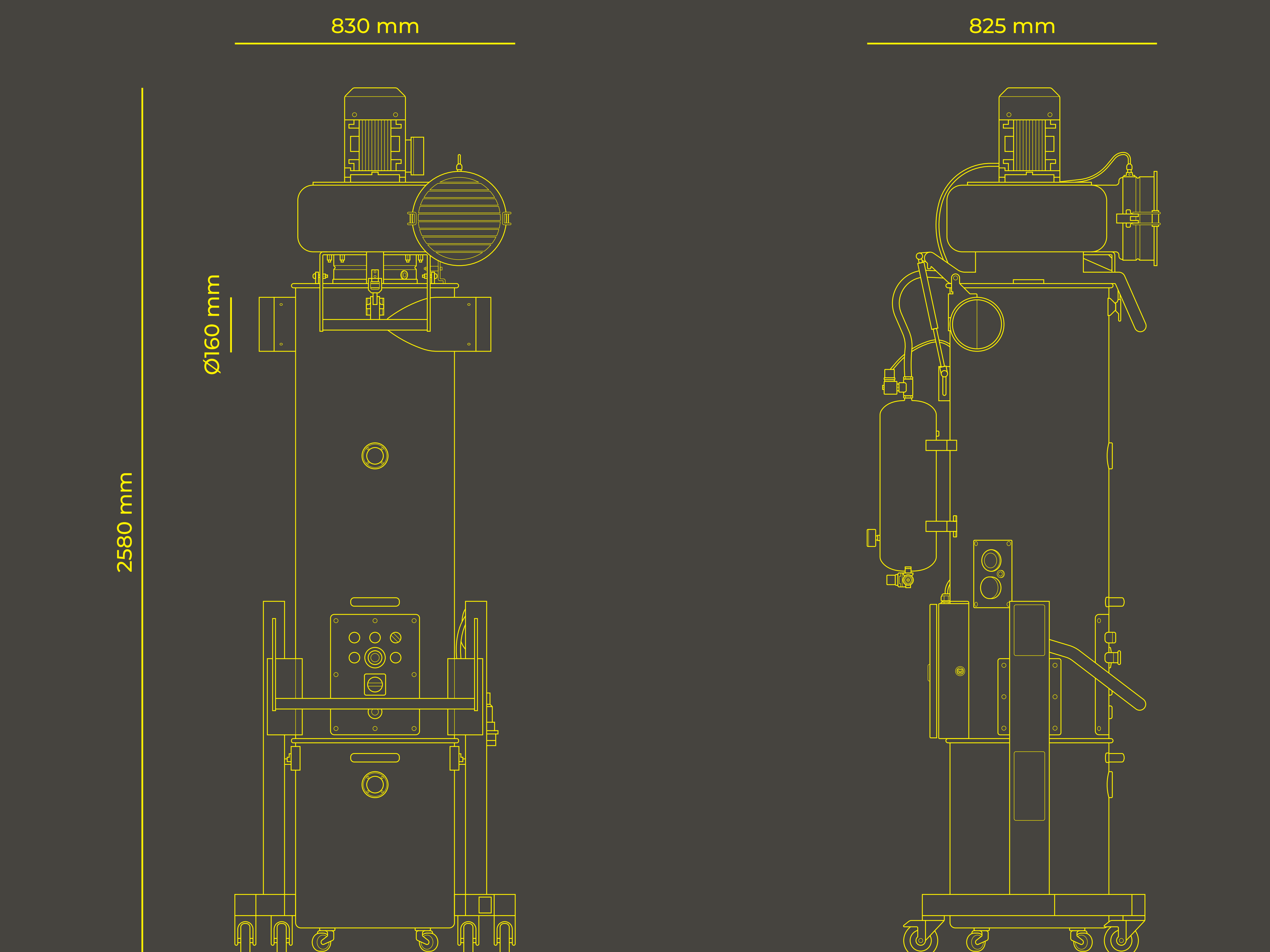

FALMACH
a brand of SIGMA INGEGNERIA
Via Provinciale di Sant'Alessio, 1957
55100 Sant'Alessio Lucca (LU) | Italy
CF | P.IVA: 01690840507
REA: LU205835

T: +39 0583 186 1320
F: +39 0583 186 1321
W: falmach.com
E: info@falmach.com